

# Inductive Sensors for can lines

Presence - Quantity - Accumulation

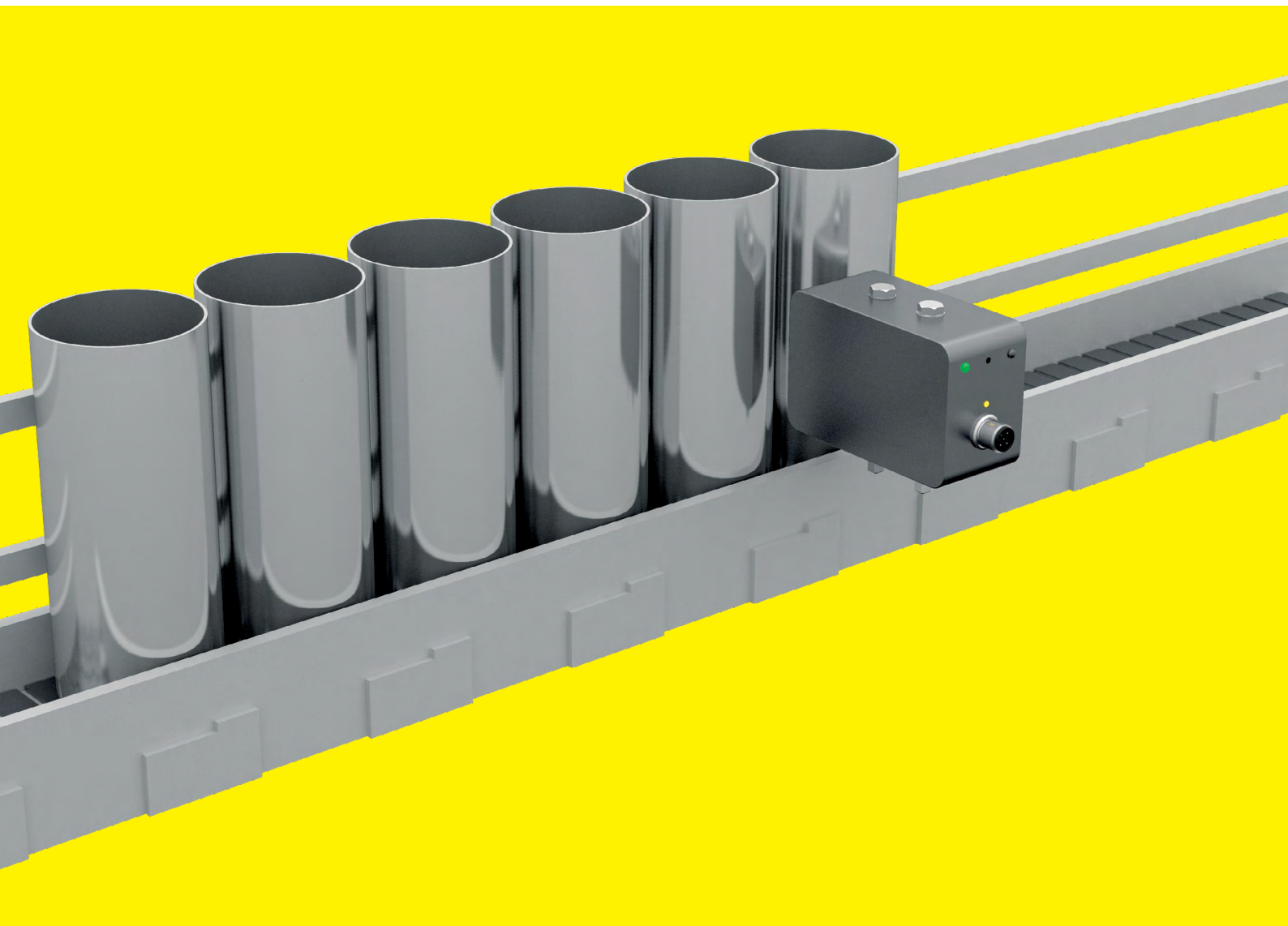

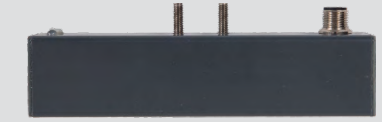
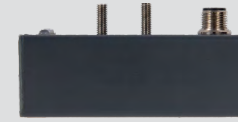

Sensor length [mm]	80		100		150		
Type	<b>IKU 008</b>	<b>DKU 008</b>	<b>IKU 011</b>	<b>DKU 011</b>	<b>IKU 015</b>	<b>DKU 015</b>	<b>DLU 001</b>
Sensitivity, adjustable	yes	yes	yes	yes	yes	yes	yes
Proxi-Teach* , possible	yes	no	yes	no	yes	no	no
Switch-on / switch-off delay, adjustable	no	yes	no	yes	no	yes	yes
Can presence detection	yes	yes	yes	yes	yes	yes	yes
Can gap detection / suppression	no	yes	no	yes	no	yes	yes
Can motion or jam detection	no	no	no	no	no	no	yes
Can size [mm]	Ø 15 - 85	≥ Ø 15	Ø 20 - 110	≥ Ø 20	Ø 25 - 160	≥ Ø 25	Ø 20 - 110
Can material	aluminum or tinplate		aluminum or tinplate		aluminum or tinplate		
Sensing distance S <sub>n</sub> [mm]	30 (referred to steel plate 80 x 50 mm)		30 (referred to steel plate 100 x 50 mm)		30 (referred to steel plate 150 x 50 mm)		
Mounting	conditionally flush		conditionally flush		conditionally flush		
Dimensions [mm]	80 x 35 x 35		100 x 35 x 35		150 x 35 x 35		
Fixing	2x threaded bolts M5 x 15		2x threaded bolts M5 x 15		2x threaded bolts M5 x 15		
Housing material	plastic		plastic		plastic		
Accessories (to be ordered separately)	mounting bracket HM7 + HM8		mounting bracket HM7 + HM9		mounting bracket HM7 + HM9		

\*Proximity switches with Proxi-Teach™ recognize the existing installation conditions after one key is pressed and adjust the operating distance optimally. The effort upon startup is minimized.

Can Count Sensor



Counting speed	<b>0 - 6000 cans / min.</b>
Type	<b>DZU 001</b>
Sensitivity, adjustable	yes, teach-in
Output	3 x PNP outputs (one can, two cans, ten cans)
Suppression of reverse movement / vibrations	yes
Number of sensors needed	1
Suitable for can size [mm]	≥ Ø 45, aluminum or tinplate
Distance to can [mm]	0,5 - 3 mm
Mounting	non flush
Dimensions [mm]	40 x 56 x 86
Fixing	2x mounting hole Ø 5,3
Housing material	plastic
Accessories (to be ordered separately)	mounting bracket HM7 + HM9

Can Area Mass Sensor

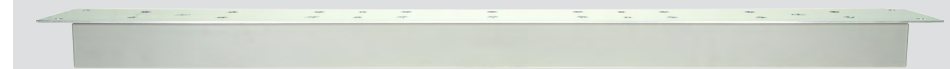

Sensing area	<b>1000 mm</b>
Type	<b>DMU 8101</b>
Can quantity min/max, adjustable	yes
Measuring range	0-100 % can accumulation on the sensing area
Output	analog 0 – 10 V or 0/4 - 20 mA
Digital interface	RS-485 (MODBUS RTU)
Suitable for can size [mm]	< Ø 70, aluminum or tinplate
Distance to the can top [mm]	8 - 15 mm
Mounting	non flush
Dimensions [mm]	1080 x 140 x 75
Fixing	4x drill holes Ø 10.5 and 4x core holes M10 x 25
Housing material	plastic
Accessories (to be ordered separately)	SIC 485 U, interface converter RS485>USB for parameterization

# Inductive Can Sensors – General Information

Can line sensors are used along conveyor lines to detect aluminum or tinplate cans. Sensing surfaces are available in different lengths, for a safe detection of different can sizes along a wide section of the conveyor segment. We offer sensors to detect the can presence, as well as versions to detect the motion, suppress gaps in can feeding, or warn of a jam condition in the flow process. A comfortable teach function makes sensor setup easy and cost-saving. Fixed or adjustable mounting brackets, for optimal mounting and alignment of the sensors on the conveyor section, complete our product range.

Proxitron can counters makes the counting of up to 6000 cans per min. possible and reliable, without remote station or double head. Thanks to the incorporated safe signal processing, counting errors due to shaking, jiggling, jumping or reverse movement of individual cans or multiple cans, are out of the question.

The can area mass sensor provides an information on the occupancy rate of the conveyor section, regardless of the can size or material. The analog output can be set according to different accumulation percentages. In combination with the drive, the analog signal can be used to adjust the conveyor speed, thus preventing excessive can pressure, or to increase the conveyor speed if can quantity is too low.

- Detection of aluminum or tinplate cans
- Can detection at the cup drawing press, body-maker, washer, feeder, drier, painting unit, printing and filling systems
- Occupancy control of conveyor sections
- Control of jam, direction, speed
- Detection or suppression of gaps in can feeding
- Can counting of up to 6000 units / min.
- No counting error due to shaking or reverse movement
- Can quantity control on the conveyor belt
- Adjustment of the feeding mass for the pressure control
- Monitoring of cup accumulation at the drawing press output or distributor
- Drawing press modulation
- Feeding pressure control
- Insensitive to dirt
- Different supply voltages and outputs available



## Type Code

Type (see table previous page)	e.g. DKU 011			
Proxi-Teach*	T			
20 - 260 V AC/DC, 2-wire normally closed		04		
20 - 260 V AC/DC, 2-wire normally open		05		
10 - 30 V DC, PNP normally closed + PNP normally open		28		
Short circuit protection			G	
Fixed connection cable**				
Plug M12x1 DC				S4
Plug 7/8" – 16 UN				S5

\*Proximity switches with Proxi-Teach™ recognise the existing installation conditions after one key is pressed and adjust the operating distance optimally. This enables safety operation under non-standard installation conditions. The effort upon startup is minimized.

\*\*Connection cables are available in standard lengths of 2, 5, 10, 15 and 20 m.